

Installation Instructions – SW3-684 TRNC[G] Range

SW3-684 - Document Version 1

A. Introduction

This document is a guideline for installation of the TRNC[G] range of transit antennas onto a vehicle roof and should be used as guidance in the context of a well-planned installation.

It should be noted that the requirements of a specific installation may differ from those outlined in this document, which gives best practice. If in any doubt, advice from installation experts or the vehicle manufacturer should be sought.



B. Important Safety Considerations



Failure to carry out an adequate risk assessments, to follow relevant laws, specifications, and best practice, and to plan installations with expert advice in respect of the matters below may increase the possibility of death, serious injury or damage to property.



Panorama strongly recommends mounting the antenna using appropriate stainless steel M12 cap head bolts, nuts and washers sealed with the supplied M12 bonded sealing washers tightened to a torque of 6Nm along with the supplied N connector mounting nuts and washers tightened to 5Nm.



Electrical Safety Note

This product contains an active GPS/GNSS antenna (part number SR8-HG26-04FJ).
Rated voltage: 3-5VDC Rated current: 20mA maximum.

The supply to these devices must be provided with overcurrent protection of 1A maximum.

B.i. Earthing-Grounding

In many installation scenarios (e.g.: where overhead lines are present) it will be extremely important to ensure that there is a low resistance contact between the antenna housing and the body of the vehicle. After the roof is prepared for installation the conductivity in the contact areas with the antenna should always be checked using an ohmmeter. In accordance with Panorama's recommendations above it is important that appropriate corrosion resistant mounting hardware is utilised for installation with washers and other ancillaries sufficient to provide and maintain the required level of contact. Where the antenna is to be fitted to a non-conductive panel an appropriate conductive mounting plate and earthing cable or similar apparatus should be employed in order to provide adequate earthing contact.

The installer should take all necessary steps to ensure that the antenna installation and mounting hardware are fully compliant with applicable regulations and industry best practice with respect to conductivity and earthing.

Continued on next page »

B.i. Sealing

The antenna is supplied with a closed cell silicone rubber sealing pad which requires a totally flat, clean and clear mounting surface of sufficient strength and a significant amount of compression in order to provide an adequate seal to the vehicle roof. These factors should be taken into account when planning the installation or alternative sealing measures should be adopted as appropriate. If mounted using the recommended fixings, then the supplied M12 bonded seal (Dowty) washers should be used. If additional sealant is used, then care should be taken to select the correct type to meet environmental durability, adequate adhesion and in particular, compatibility with the antenna component material.

It is extremely important that any measures taken to seal the mounting bolts do not impact upon the earthing contact they provide between the vehicle body and the antenna.

B.iii. Other Safety Considerations

The installation should always be planned to take account of any other applicable safety concerns. These should be established through an appropriate risk assessment exercise. Other factors which may need to be considered are the strength of the mounting panel and hardware in event of impact, the position of the antenna, which should be adequately protected from any impact which may damage the antenna and installation location, and the height of the installation which should be compliant with the relevant regulations. The antenna install location should be safely accessible by installation personnel.

C. Planning & Preparation

Select an installation location, with the antenna sited a minimum of 1m (3') away from existing roof structures. Check clearance under the panel, considering the depth required for mating connector(s). For cellular LTE variants (TRNC[G]-7-60-NJ), the antenna should be fitted in the centre of a metallic (conductive) ground plane of minimum size 250mmx250mm (10"x10") or 600mm x 600mm (2' x 2') for UHF variants (e.g.: TRNC[G]-TET-NJ). If fitting to a non-conductive panel, a ground plane plate of above minimum dimension should be fitted to the underside of the panel. In both these cases, the antenna must make low resistance contact with this plate ($<0.1\Omega$) using the mounting bolts and washers. In some cases, it may be better to mount the antenna on a separate flange with integrated mounting bolts, which is then welded to the roof panel.

D. Drilling Holes

Drill mounting and connector holes as appropriate. The supplied drilling template (SW3-320) can be utilised as a guide if required. NOTE: Do NOT use a photocopy of the template as it may not be 1:1 scaled! Clearance holes for the connectors should not exceed 24mm diameter to avoid encroaching on the sealing area. Clean the area around the holes, removing all burrs and swarf. Apply a conductive corrosion resistant coating or paint to bare metal surfaces to prevent corrosion.

E. Fitting

Ensure that the mounting panel is clean and flat within the antenna base footprint area. Place the antenna in position, check that the mounting holes are aligned, check that the connectors have adequate clearance through the holes and are accessible from the underside. Fit the bolts with washers and lightly tighten, checking that the sealing pad is compressing evenly. Finally tighten all bolts to the recommended torque setting.

F. Route and Connect Coaxial Cables

Plan the cable routing to take into account the minimum bend radius for the cable type used. The cable should be routed to avoid running parallel to existing wiring or fouling any moving controls or components. Fit connector to suit both the equipment and cable to type and consider securing to avoid coming loose in service.

Continued on next page »

G. Test and Commission

The comms antenna elements are d.c. grounded and will present a short circuit. In order to test this antenna disconnect the comms cable from antenna, the connector body to centre pin (on the cable) should measure open circuit. Reconnect the comms cable to antenna and the connector body to centre pin (on the cable) should measure short circuit. With the GPS cable connected to the GPS antenna port the connector body to centre pin should measure high resistance. It is recommended to carry out a VSWR check, this should measure <2.5:1.

H. Cleaning and Maintenance

The antenna should not be cleaned with or exposed to strong base or solvent cleaners. The antenna should not be exposed to excessive oil and grease. Once installed it is not recommended to remove or re-fit the antenna. The antenna should be checked periodically for signs of damage.

I. Notices



European Waste Electronic Equipment Directive 2002/96/EC

Please ensure that your old Waste Electricals and Electronics are recycled do not throw them away into standard waste.



R&TTE: DIRECTIVE 1999/5/EC of 9 March 1999 on radio equipment and telecommunications terminal equipment and the mutual recognition of their conformity. Compliance is declared according to: **EN 301 489-1 V1.9.2** – Electromagnetic compatibility and radio spectrum matters (ERM); Electromagnetic compatibility (EMC) standard for radio equipment and services; Part 1: Common technical requirements - Referencing **EN 301 489-3 V1.6.1** and **EN 300 440-1 V1.6.1 (2010-08)** – Electromagnetic compatibility and radio spectrum matters (ERM); short range devices; radio equipment to be used in the 1GHz to 40GHz frequency range; Part 1: Technical characteristics and Test methods in accordance with **EN 300 440-2 V1.4.1 (2010-8)** - Electromagnetic compatibility and radio spectrum matters (ERM); short range devices; radio equipment to be used in the 1GHz to 40GHz frequency range; Part 2: Harmonised EN covering the essential requirements of article 3.2 of the R&TTE Directive.

Low Voltage Directive: Directive 2006/95/EC (Electrical Equipment designed for use within certain voltage limits) of August 2007. Compliance is declared according to: EN60950-1: Safety of information technology equipment – according to test specification **EN 60950-1:2006** +A11:2009 +A1:2010 +A12:2011.

Waiver: This document represents information compiled to the best of our present knowledge. It is not intended to as a representation or warranty of fitness of the products described for any particular purpose. This document details guidelines for general information purposes only. Always seek specialist advice when planning installations and ensure that antennas are always installed by a properly qualified installer in compliance with local laws and regulations.

Mounting Instructions

TRNC[G] Series

TRNC[G] Install Guide - Document Version 1

1. Mounting Surface

Ensure that mounting surface is flat and clean.

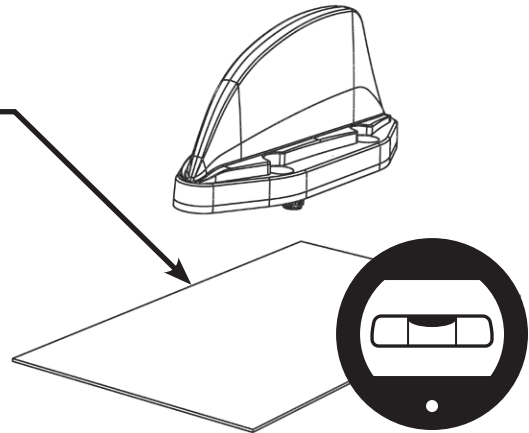

2. Drilling of Boreholes

Use drilling template supplied for all required holes. Remove all burrs and sharp edges from holes.

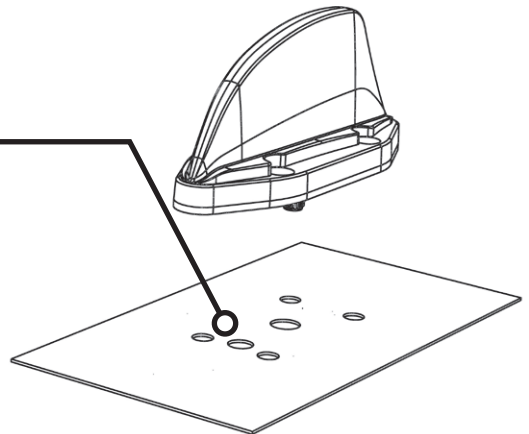

3. Mounting

Mount to panel using M12 hexagon socket head cap screws and supplied M12 sealing washers (supplied).

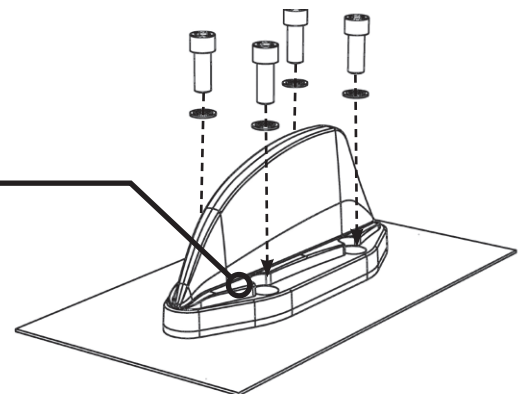
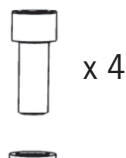

Continued on next page »

4. Washer Assembly

On under side of panel, assemble M12 hexagon socket head cap screws with suitable M12 nuts and washers. Assemble N-connector nut, shake proof washer and washer.

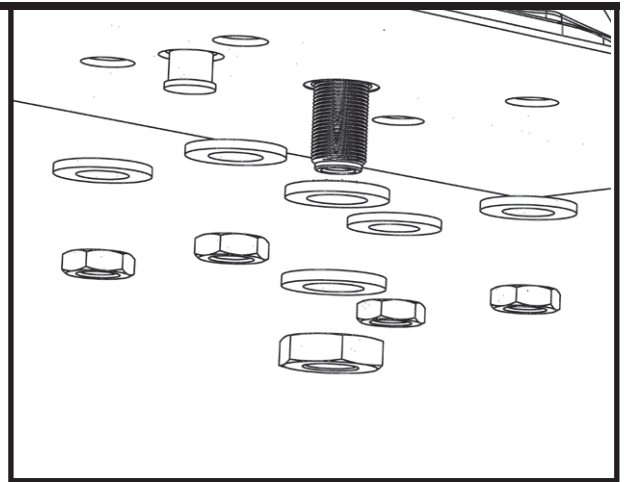

5. Tighten

Tighten the N connector nut to 5Nm and the four outer nuts to 6Nm.

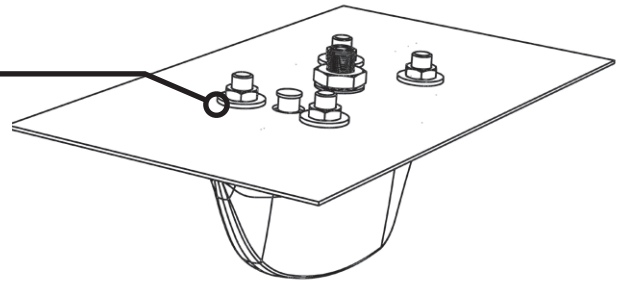

6. Seal and Cap

Seal area between M12 screws and antennas base with a suitable silicone sealant and assemble M12 screw caps (supplied).

